



No.:1 Equipment No.:

Project Name:Untitled

Date:2024-11-18

Remarks:

Input Parameters	
Air Volume	9500 m3/h
Input S.P.	450 Pa
Fan Parameters	
Type	LKT12-12R
Air Volume	9500 m3/h
Total Pressure	680 Pa
Static Pressure	450 Pa
Dynamic Pressure	230 Pa
Outlet Velocity	19.59 m/s
Total Efficiency	55.9 %
Fan Speed	1230 r/min
Shaft Power	3.21 kw
Motor Parameters	
Motor Power/Pole	4/4
Motor Speed	1440 r/min
Elec Supply V/Ph/Hz	380/3/50
Belt/Pulley	
Fan Pulley/Bush/Shaft	
Motor Pulley/Bush/Shaft	
Belt Model * qty	
Belt Length/Belt Speed	
Bearing life L10/L50 (h)	h
Machine Parameters	
Total Weight	73.6 kg

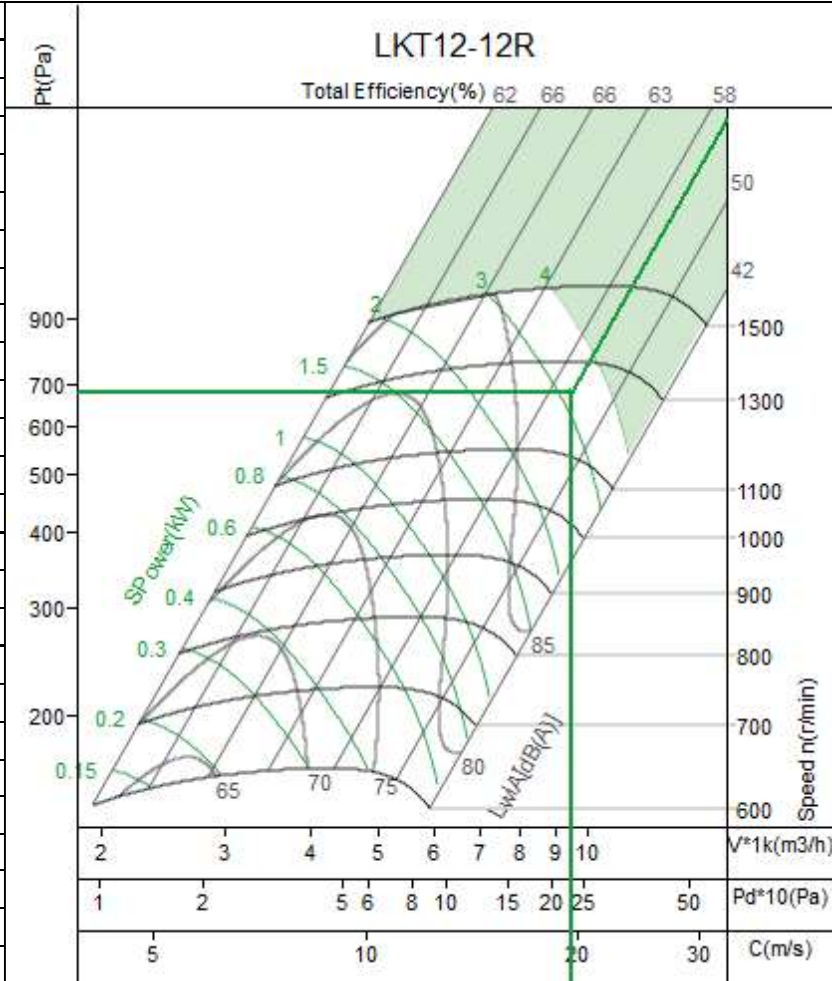

Limiting Parameters		Noise									
Max. Fan Speed	1500 r/min	HZ	63	125	250	500	1k	2k	4k	8k	Overall
Max. Absorbed Power	4 kw	Lw	81	84	83	84	83	83	81	76	91
Temperature(Min-Max)	-20~85 jæ	Lw(A)	55	68	74	81	83	84	82	75	89
Max. Bearing Load	14000 N	LpA	47	60	66	73	75	76	74	67	81

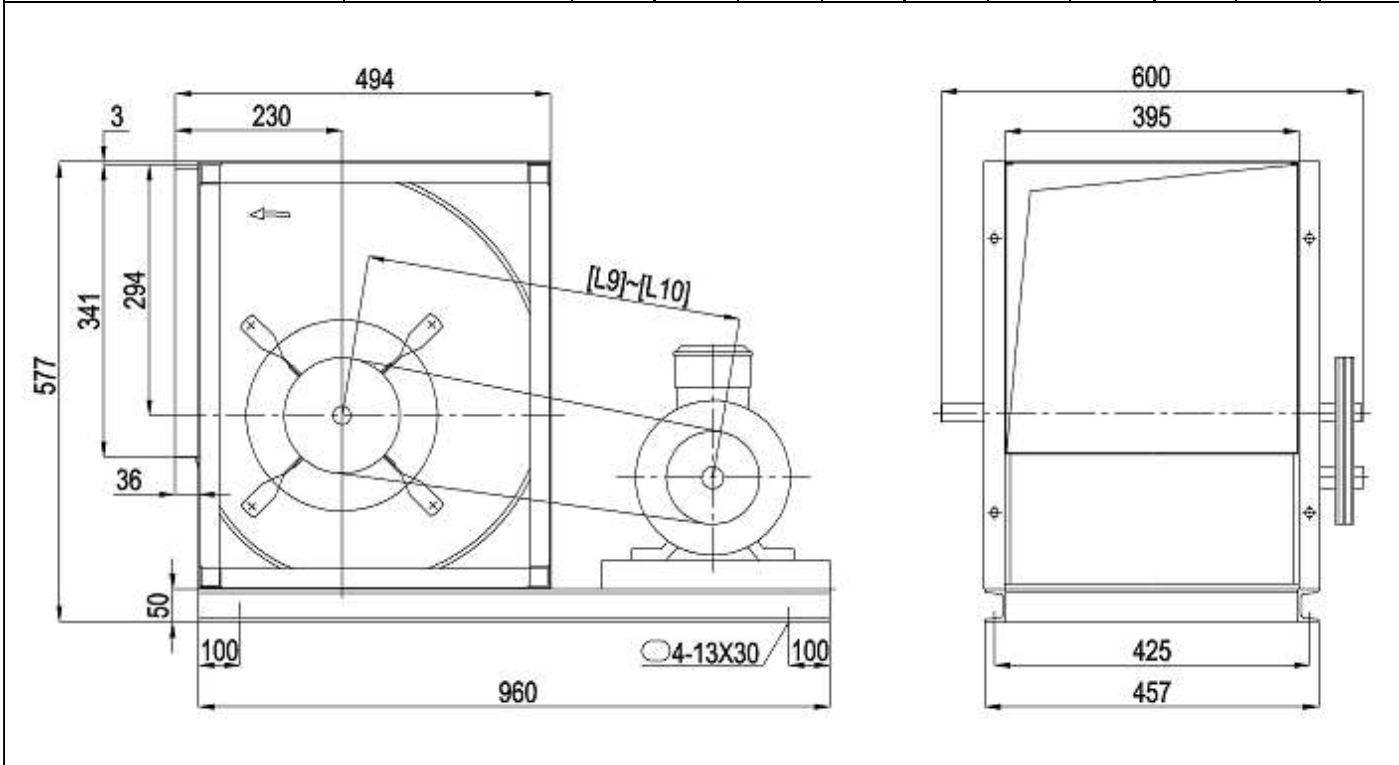

Fan Section

PRE FILTER



model	Overall dimensions (MM)							
	A	B	C	D	e1	e2	a1	a2
AT 15-15	1150	1150	1450	100	920	380	470	405

