



No.:1 Equipment No.:

Project Name:Untitled

Date:2024-11-18

Remarks:

Input Parameters	
Air Volume	12000 m3/h
Input S.P.	400 Pa
Fan Parameters	
Type	LKT15-15RK
Air Volume	12000 m3/h
Total Pressure	584 Pa
Static Pressure	400 Pa
Dynamic Pressure	184 Pa
Outlet Velocity	17.52 m/s
Total Efficiency	60.6 %
Fan Speed	945 r/min
Shaft Power	3.21 kw
Motor Parameters	
Motor Power/Pole	4/4
Motor Speed	1440 r/min
Elec Supply V/Ph/Hz	380/3/50
Belt/Pulley	
Fan Pulley/Bush/Shaft	
Motor Pulley/Bush/Shaft	
Belt Model * qty	
Belt Length/Belt Speed	
Bearing life L10/L50 (h)	h
Machine Parameters	
Total Weight	85.3 kg

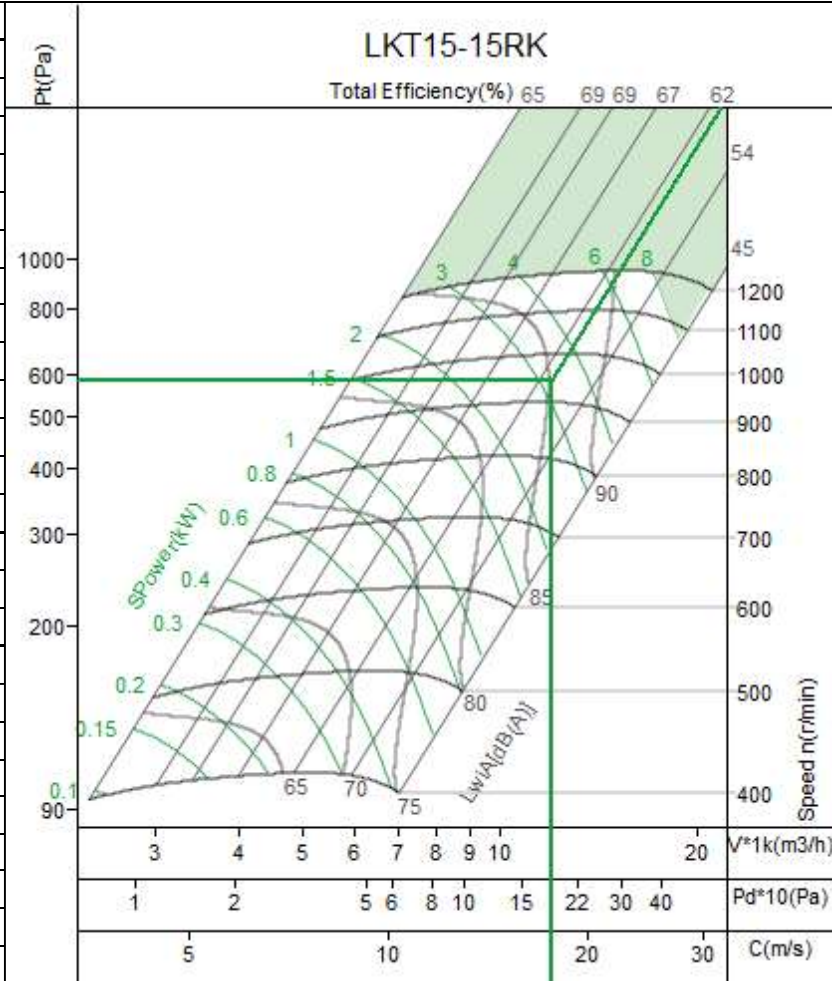

Limiting Parameters		Noise									
Max. Fan Speed	1200 r/min	HZ	63	125	250	500	1k	2k	4k	8k	Overall
Max. Absorbed Power	8 kw	Lw	79	84	79	81	80	79	78	73	89
Temperature(Min-Max)	-20~85 jæ	Lw(A)	52	68	70	78	80	80	79	72	86
Max. Bearing Load	19400 N	LpA	44	60	62	70	72	72	71	64	78

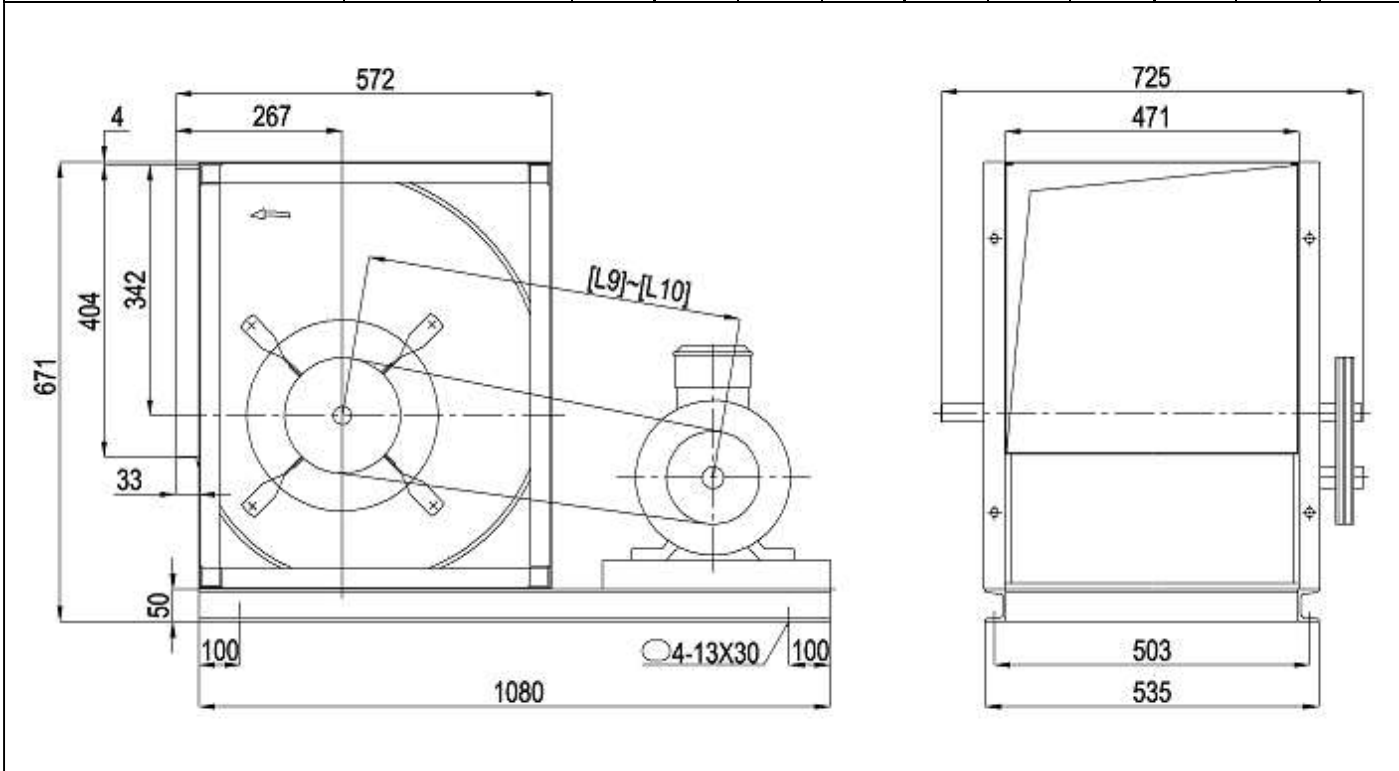

Fan Section

PRE FILTER



model	Overall dimensions (MM)							
	A	B	C	D	e1	e2	a1	a2
AT 15-15	1150	1150	1450	100	920	380	470	405

